



**Cycle Storage, Racking  
and Security products**

**Shelford Design Ltd.**

P.O. Box 255, Chestfield,  
Whitstable, Kent, CT5 3XW

t: 07767 484 465 f: 01227 791 853

e: sales@tuskstore.com w: www.tuskstore.com

- Also available:
- TUSK Hook 'n' Hang vertical bike storage
  - TUSK Excel high security anchors
  - TUSK Bull Rack bike storage
  - TUSK Multihanger overhead storage

For more details, see our website at [www.tuskstore.com](http://www.tuskstore.com)

**Product Information: TUSK MAXI MODULAR BIKE PARK KITS**

**18**

**Architects, Planners and Installers' notes** • for all Maxi back to back kits • See also Sheet 22: PLANNING YOUR SPACE to get the best installation

**INSTALLATION:**

1. Fully assemble complete **Bike Park** kit as shown
2. Position **Bike Park** in required location.
3. At each end of each **Floor Bar** drill through holes in **Floor Bars** into the floor with an 8mm dia. drill x 50mm deep hole.
4. Insert drill through bolt, tap end to expand sleeve and tighten nut.
5. Cut off any excess thread.
6. Tap into place and install armour ring security shields to all exposed fastener heads.

If in doubt on any aspect contact us by email or call 07767 484 465.

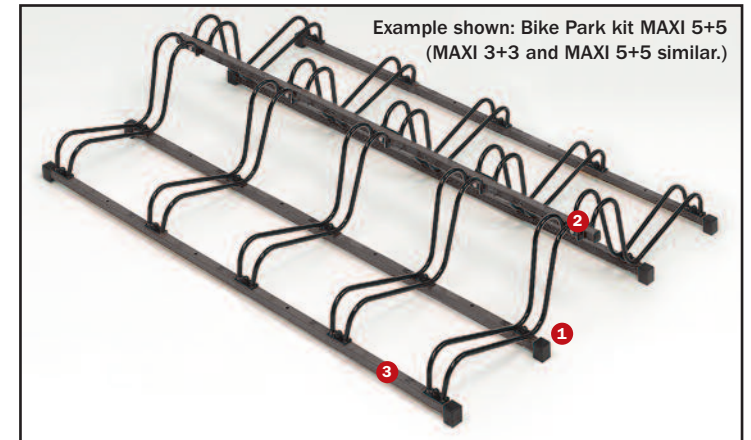

**1 Bike Park to floor bar assembly**

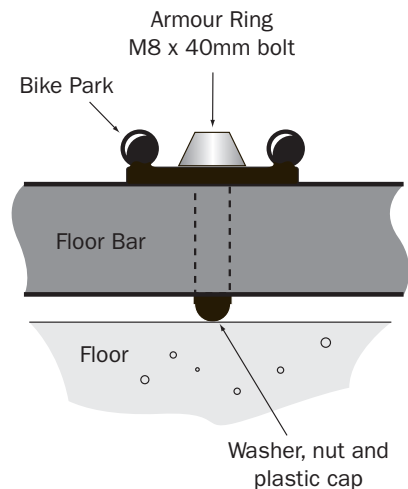

**2 Bike Park to centre spacer bar assembly**

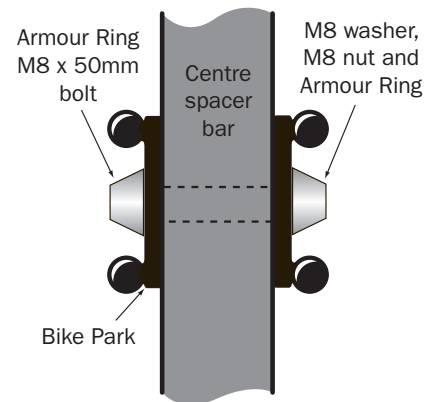

**3 Floor Bar to floor installation (2 places per Floor Bar)**

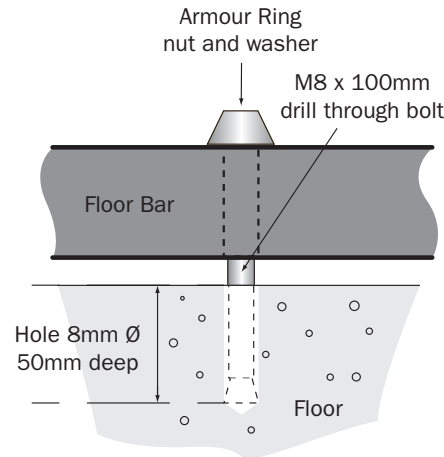

**Armour Ring Fastener Security (Home Office Approved)**

