



**Cycle Storage, Racking  
and Security products**

**Shelford Design Ltd.**

P.O. Box 255, Chestfield,  
Whitstable, Kent, CT5 3XW

t: 07767 484 465 f: 01227 791 853

e: sales@tuskstore.com w: www.tuskstore.com

- Also available:
- TUSK Hook 'n' Hang vertical bike storage
  - TUSK Excel high security anchors
  - TUSK Bull Rack bike storage
  - TUSK Multihanger overhead storage

For more details, see our website at [www.tuskstore.com](http://www.tuskstore.com)

**Product Information: TUSK MAXI MODULAR BIKE PARK KITS**

**17**

**Architects, Planners and Installers' notes** • for all Maxi single row kits • See also Sheet 21: PLANNING YOUR SPACE to get the best installation

**INSTALLATION:**

1. Fully assemble complete **Bike Park** kit as shown in photograph.
2. Position completely assembled **Bike Park** kit with uprights against the wall. Mark hole positions in wall with 8mm masonry drill.
3. Remove **Bike Park** kit.
4. Drill a 14mm hole at each location x 55mm deep.
5. Finger tighten a bolt into the shield anchor prior to inserting into brickwork flush to wall surface.  
Give 2-3 turns of the bolt to expand the shield anchor in the wall then remove the bolt.

6. Bolt **Bike Park** to wall with M8 x 60mm bolts + thin washer.
7. At each end of each **Floor Bar** drill through holes in **Floor Bars** into the floor with an 8mm dia. drill x 50mm deep hole.
8. Insert drill thro bolt, tap end to expand sleeve and tighten nut.
9. Cut off any excess thread.

If in doubt on any aspect contact us by email or call  
**07767 484 465.**

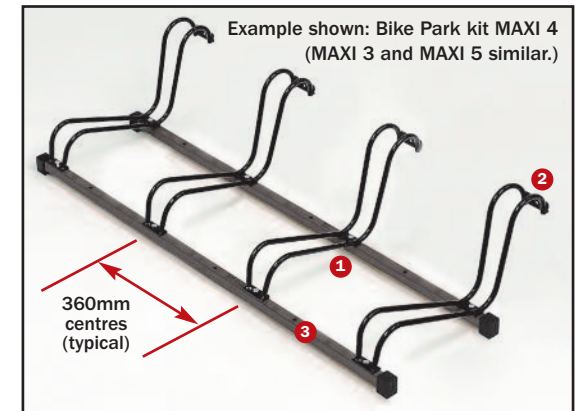

**1 Bike Park to floor bar assembly**

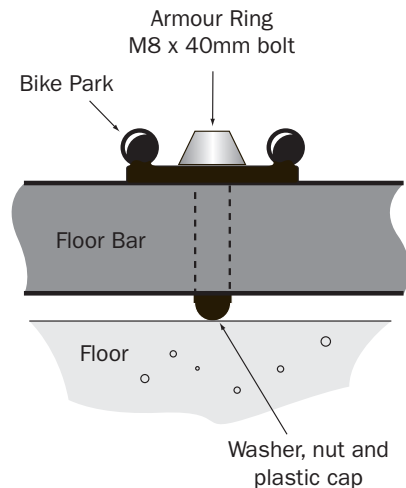

**2 Bike Park to wall assembly**

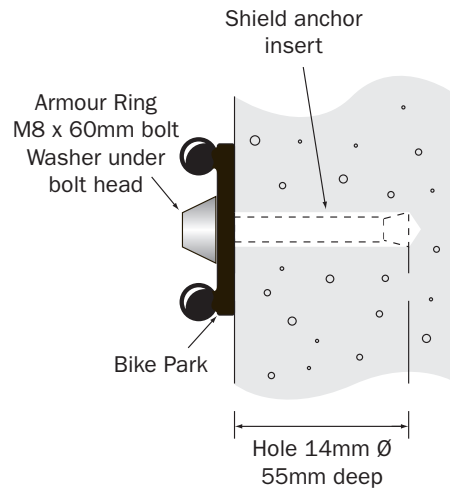

**3 Floor Bar to floor installation (2 places per Floor Bar)**

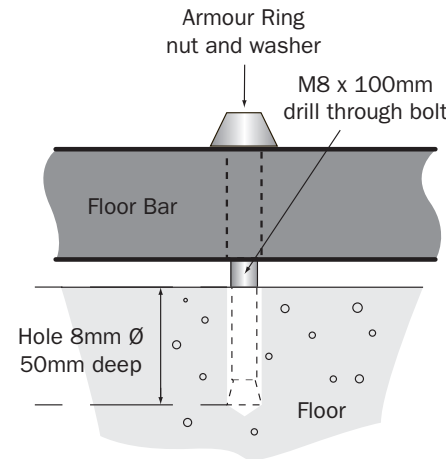

**Armour Ring Fastener Security (Home Office Approved)**

